

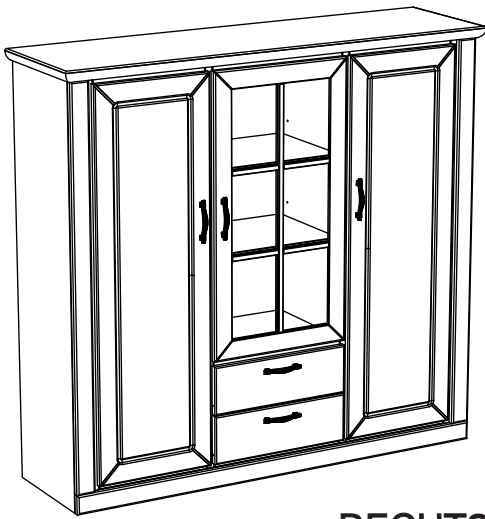

LINKS ver.



RECHTS ver.

Assembled size / Maße aufgebaut :

Height / Höhe : 1344 mm.

Width / Breite : 1444 mm.

Depth / Tiefe : 405 mm.

This unit can be assembled by two persons.

Aufbau mit zwei Personen.

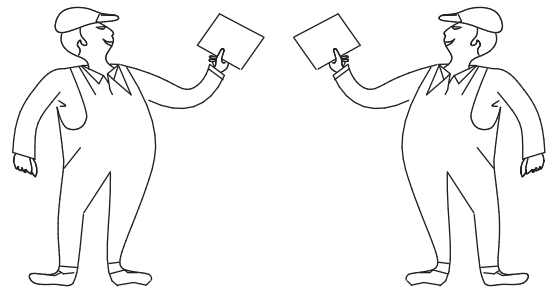

The necessary tools (not included)

Die dazu benötigten Werkzeuge (ausschliesslich)

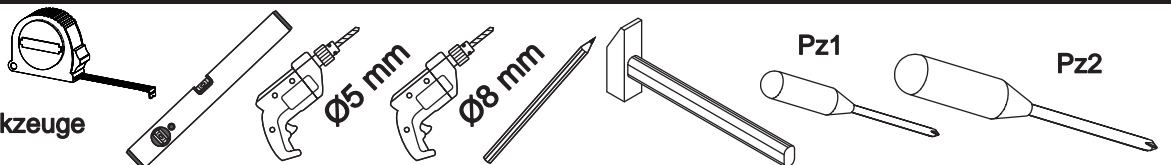

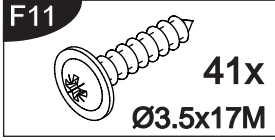
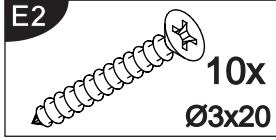
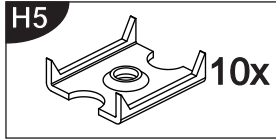
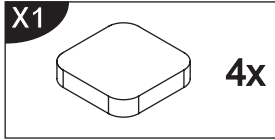
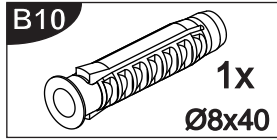
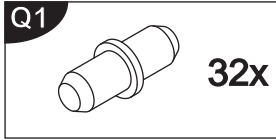
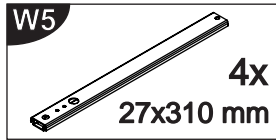
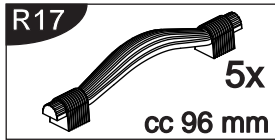
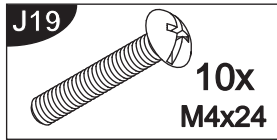
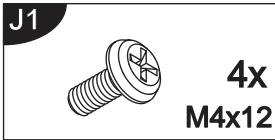
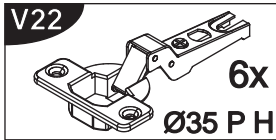
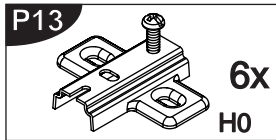
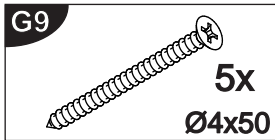
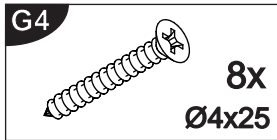
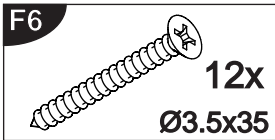
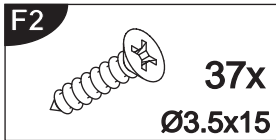
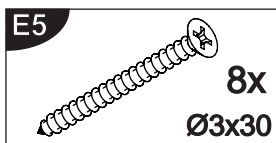
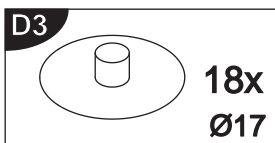
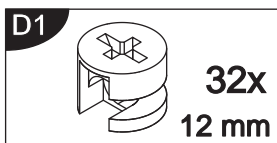
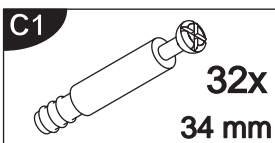
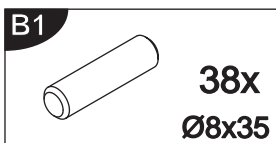
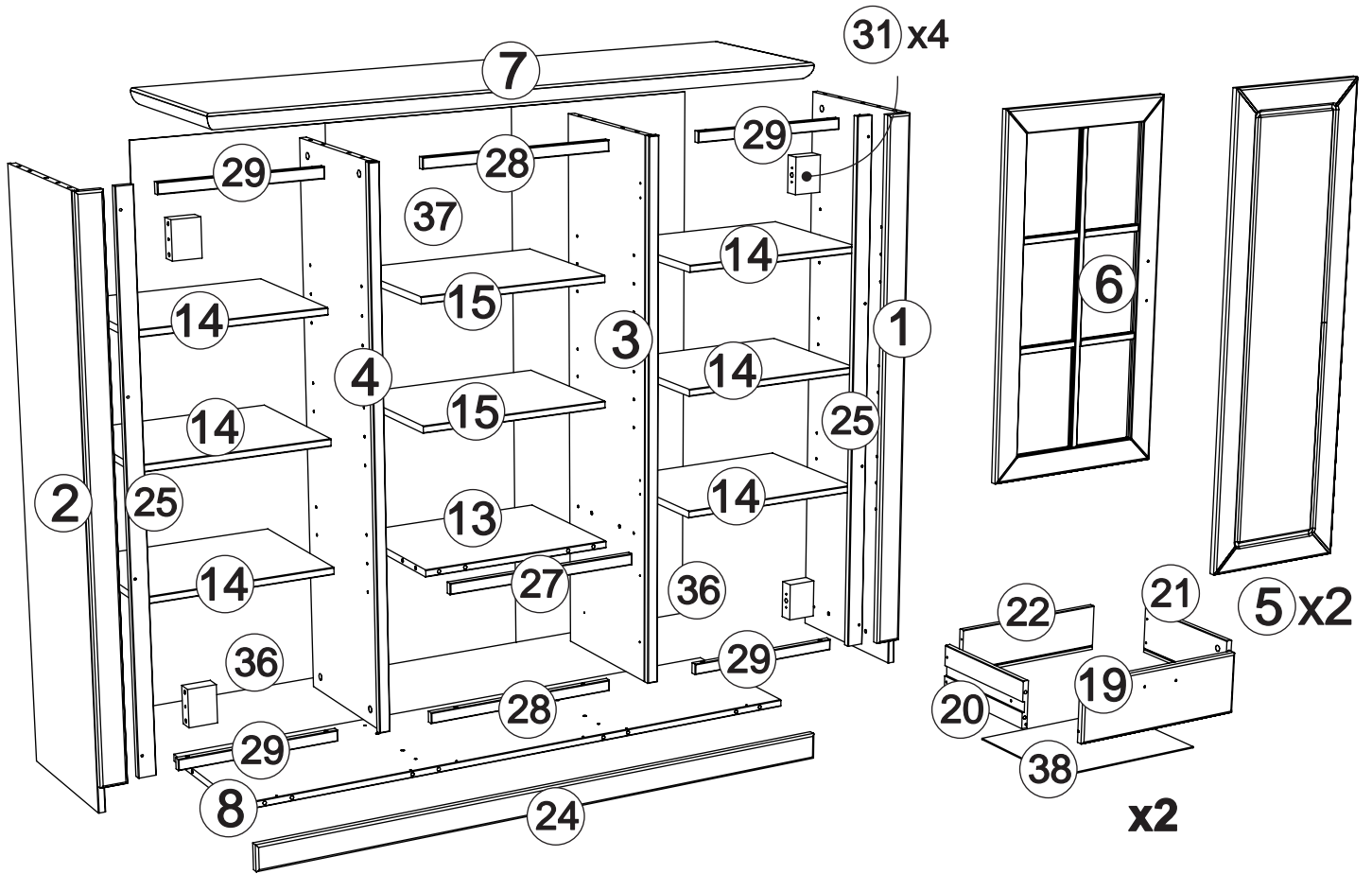

1

B1 x 26

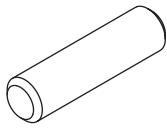

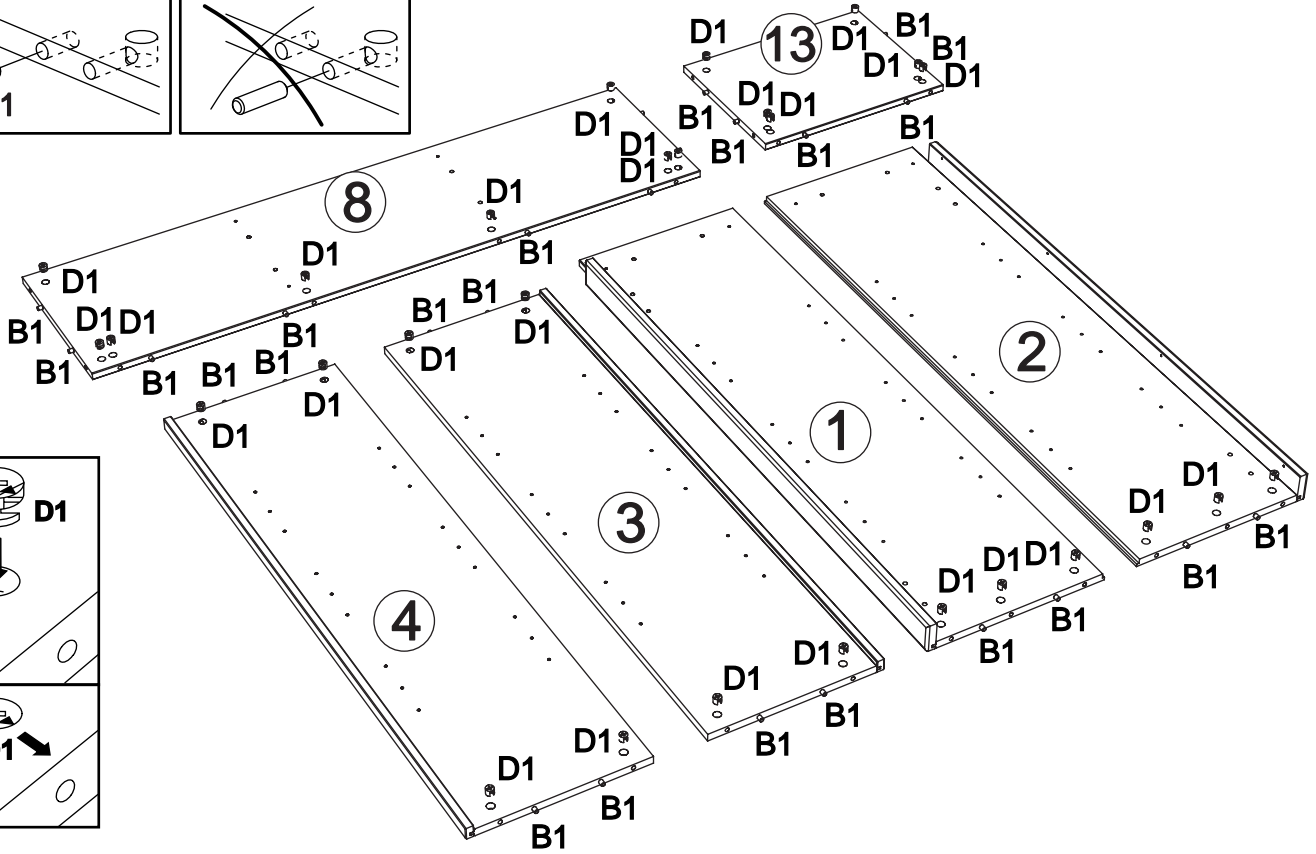
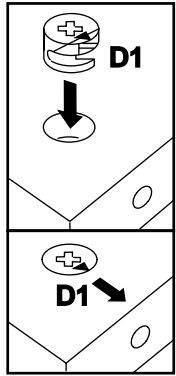
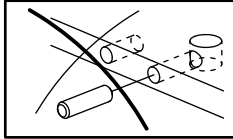
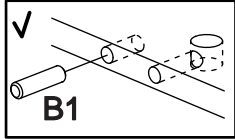
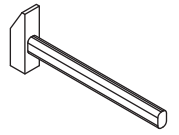
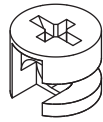

D1 x 28

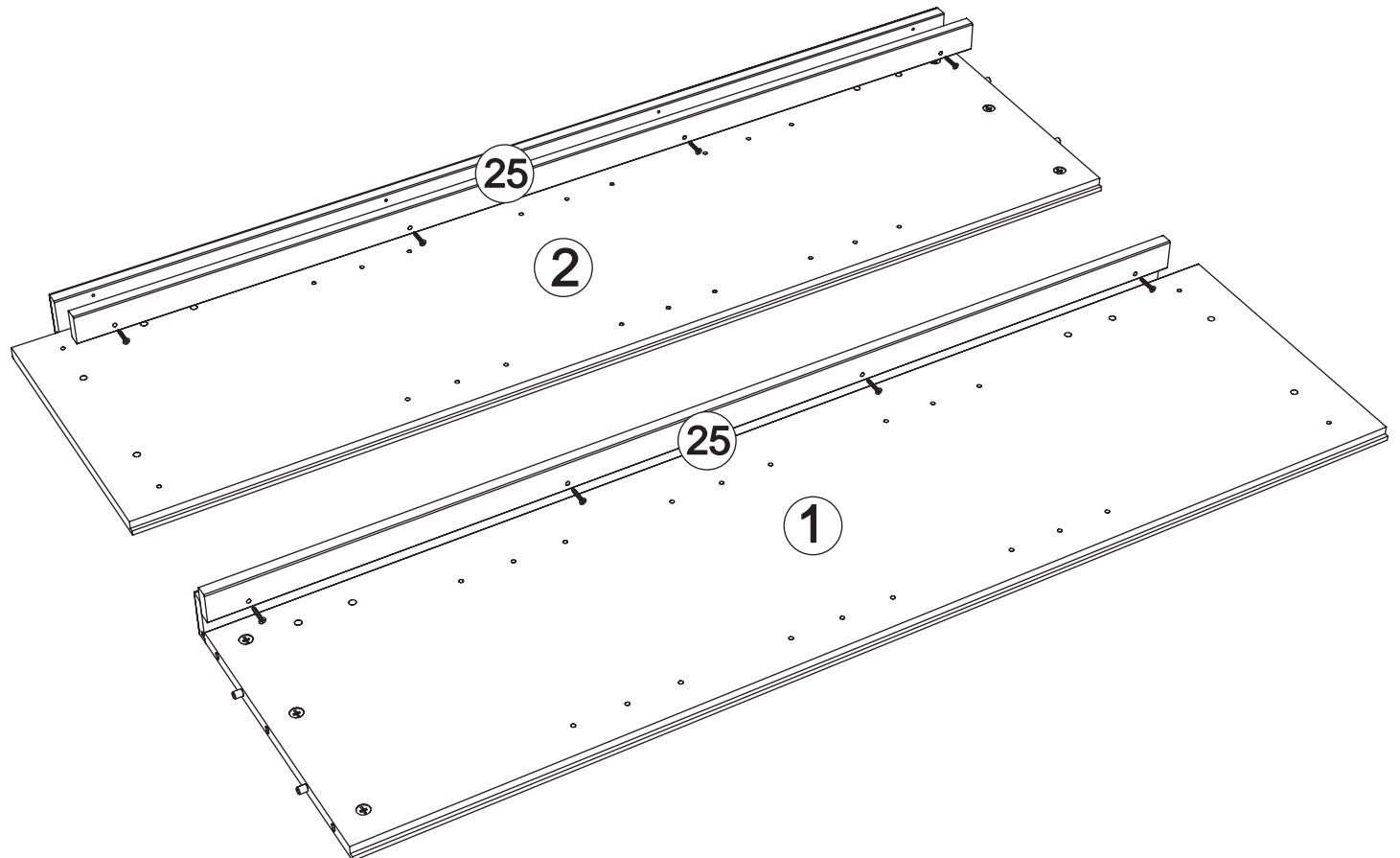
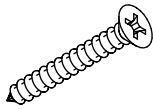

2

G4 x 8

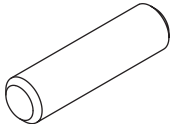
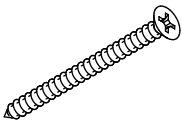

3 B1 x 8  G9 x 4    PZ2

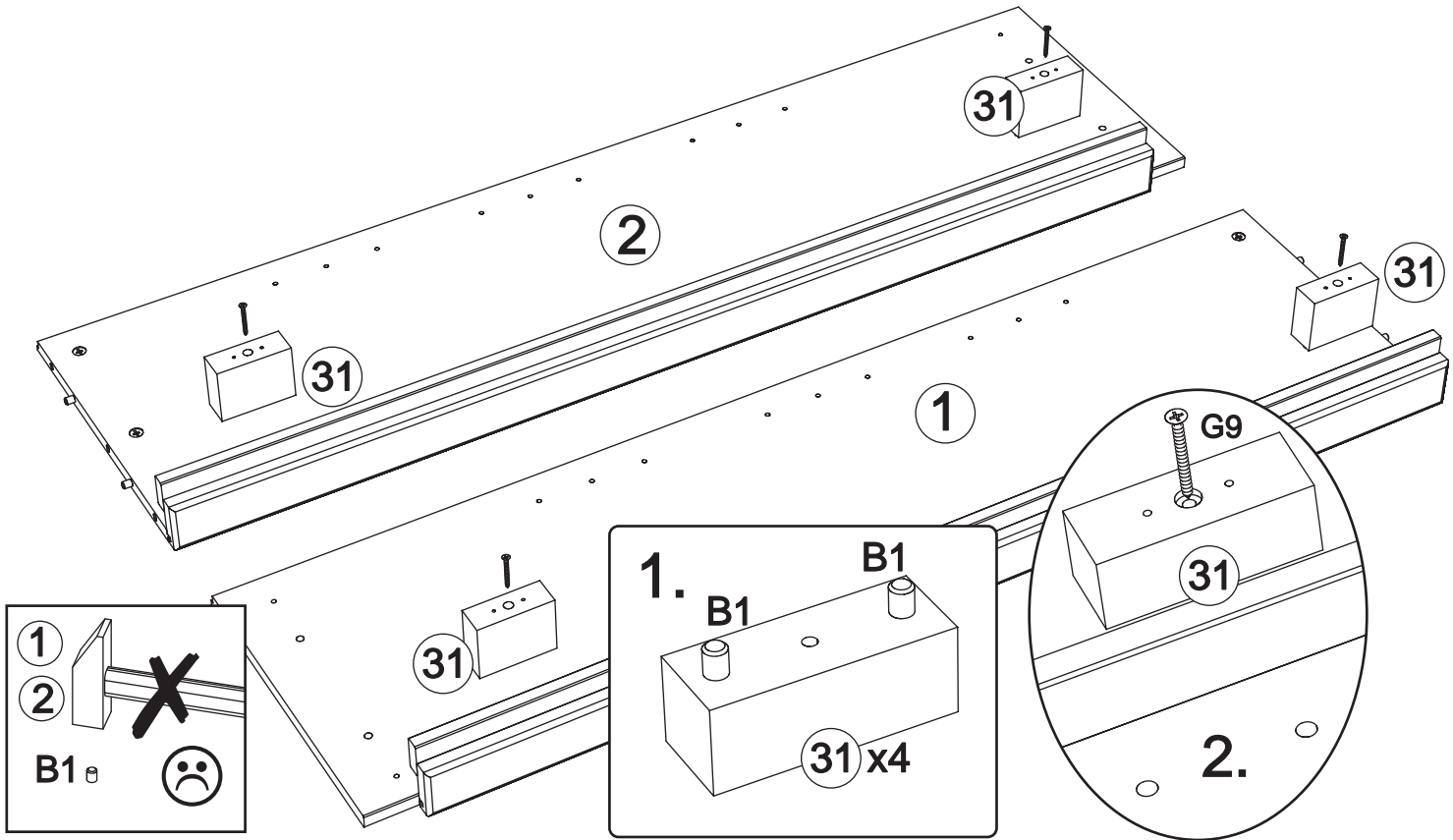

4 C1 x 28    PZ2

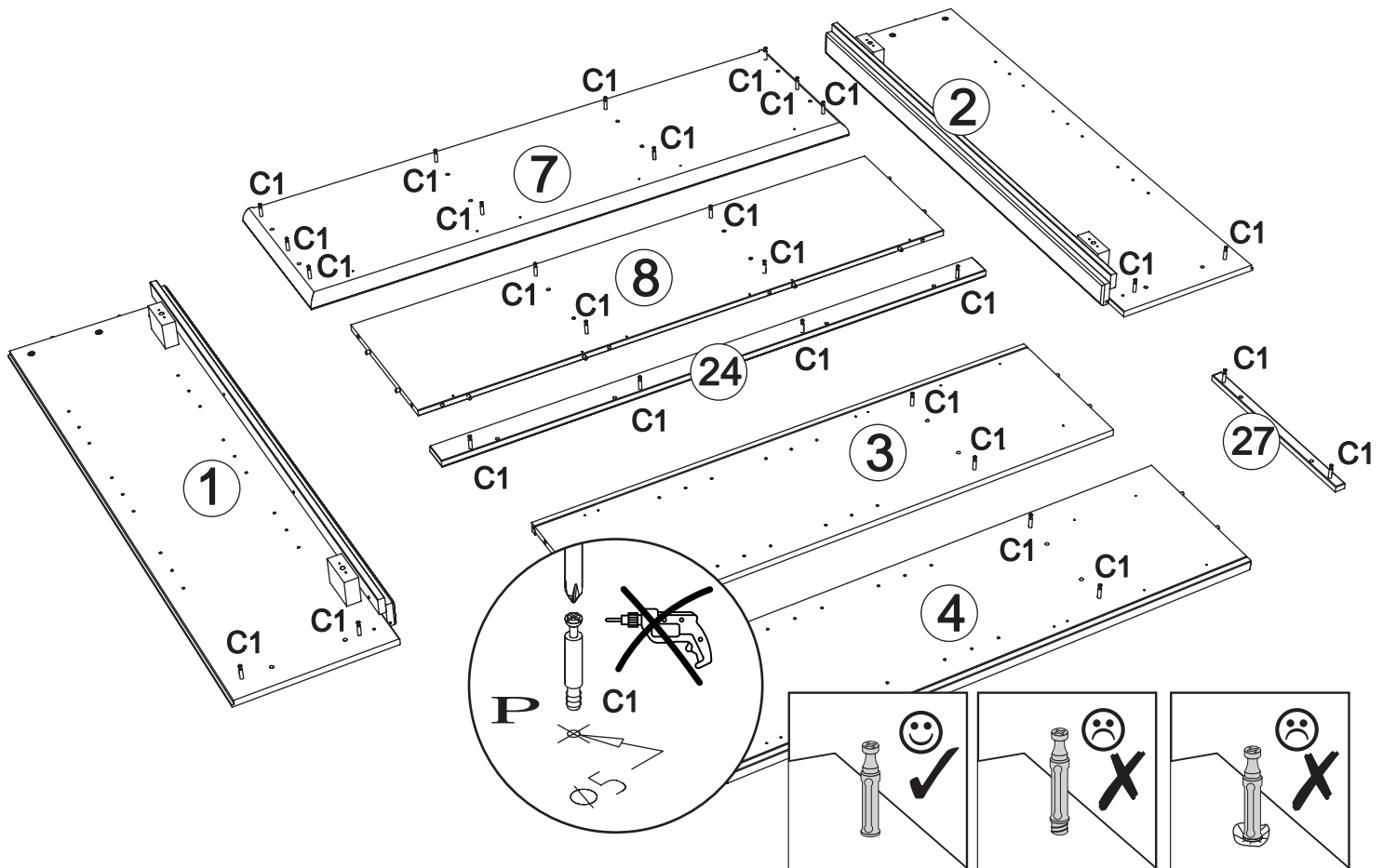

5

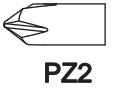

PZ2

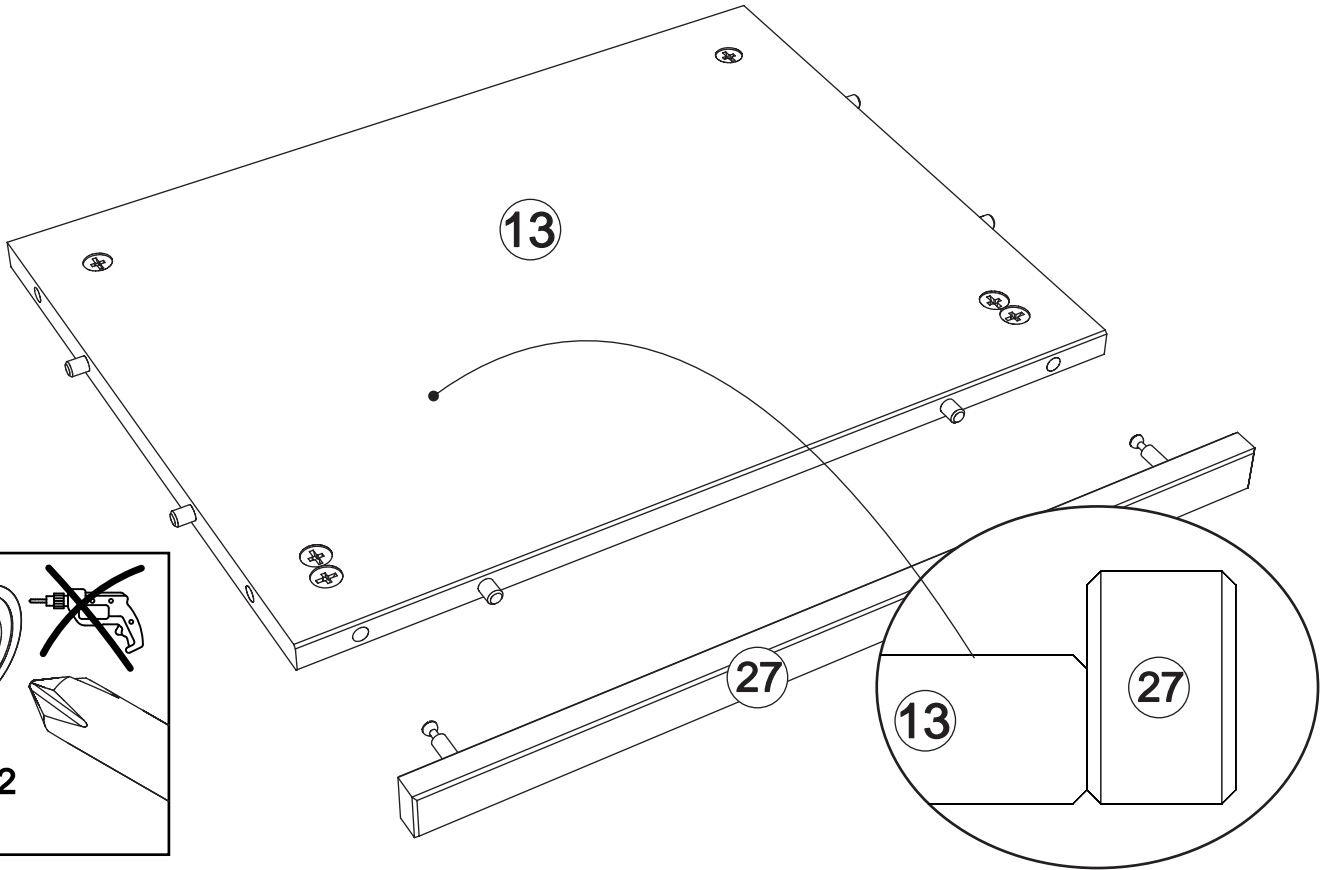

D1 x 2

6

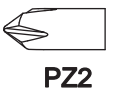

PZ2

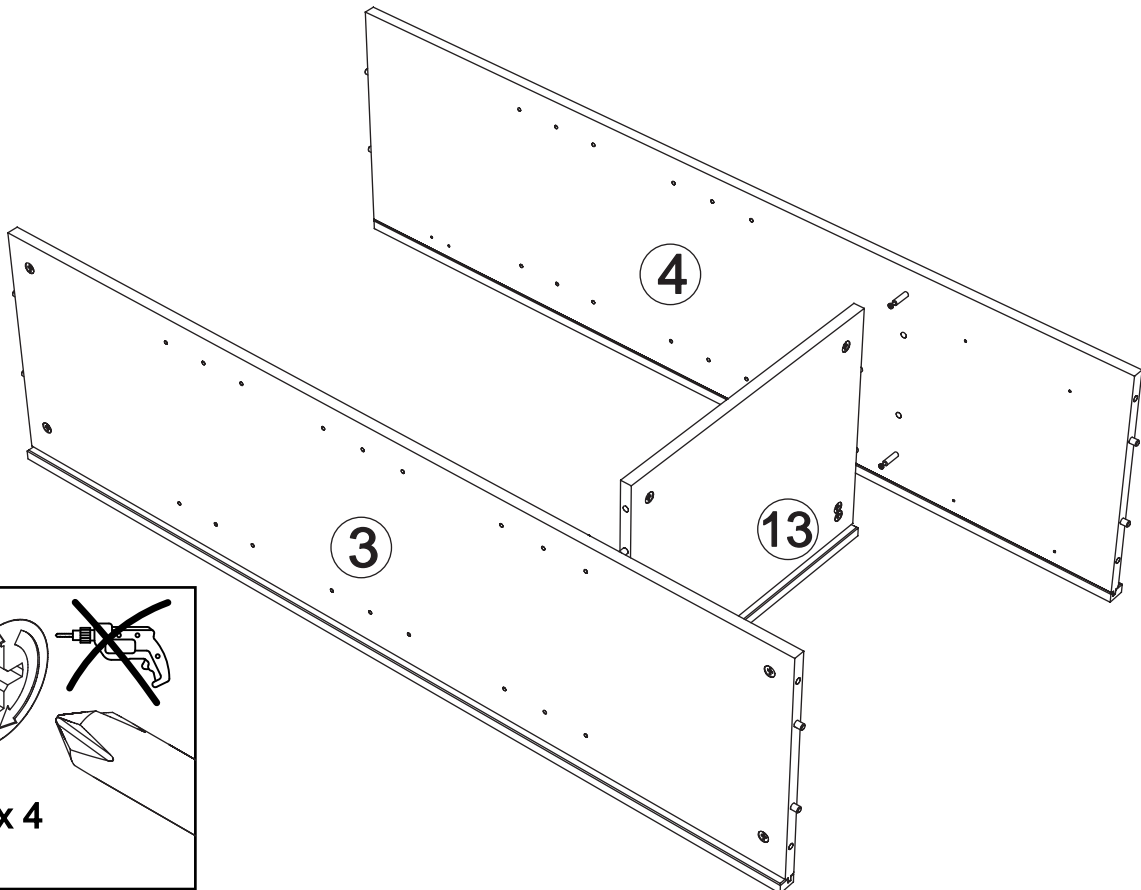

D1 x 4

7

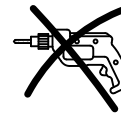

PZ2

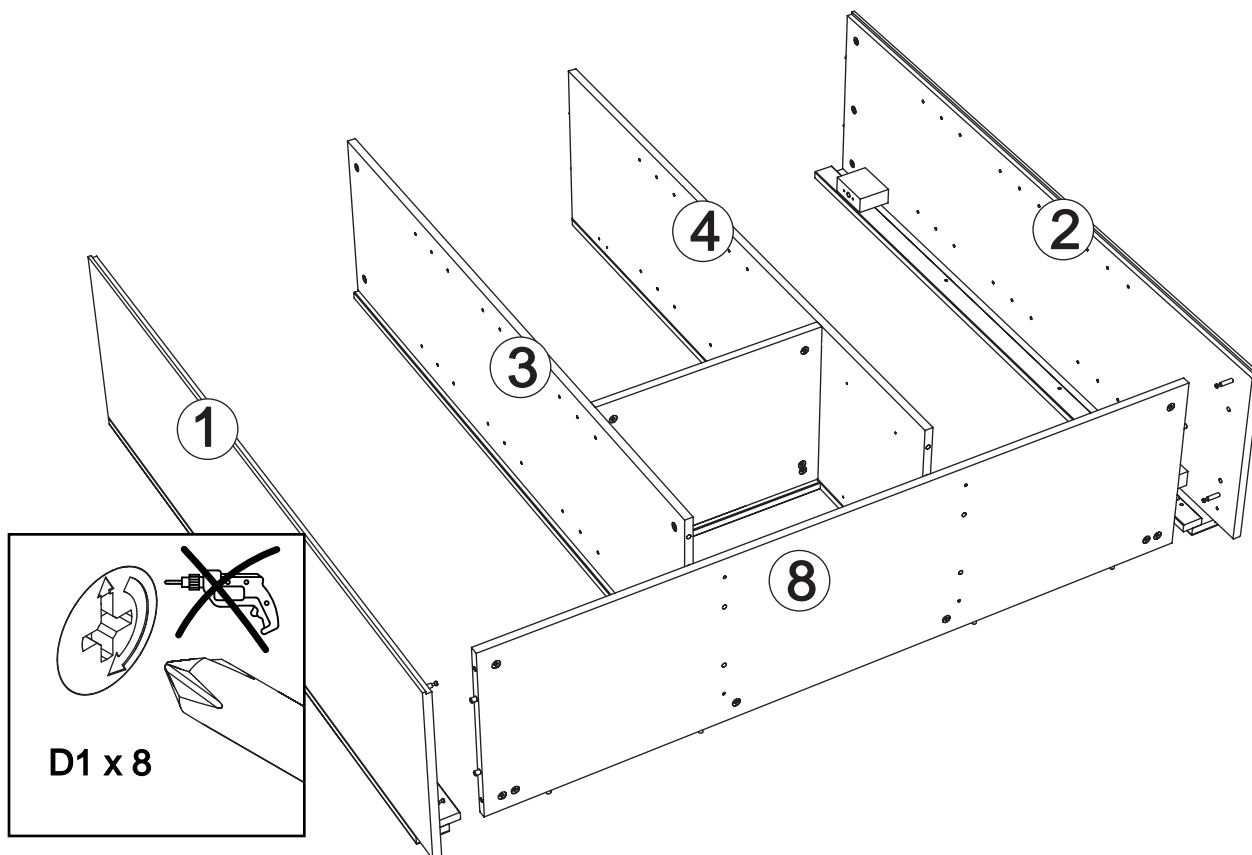

8

F2 x 4

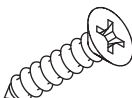

L15 x 2

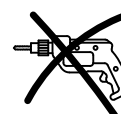
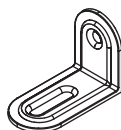

PZ2

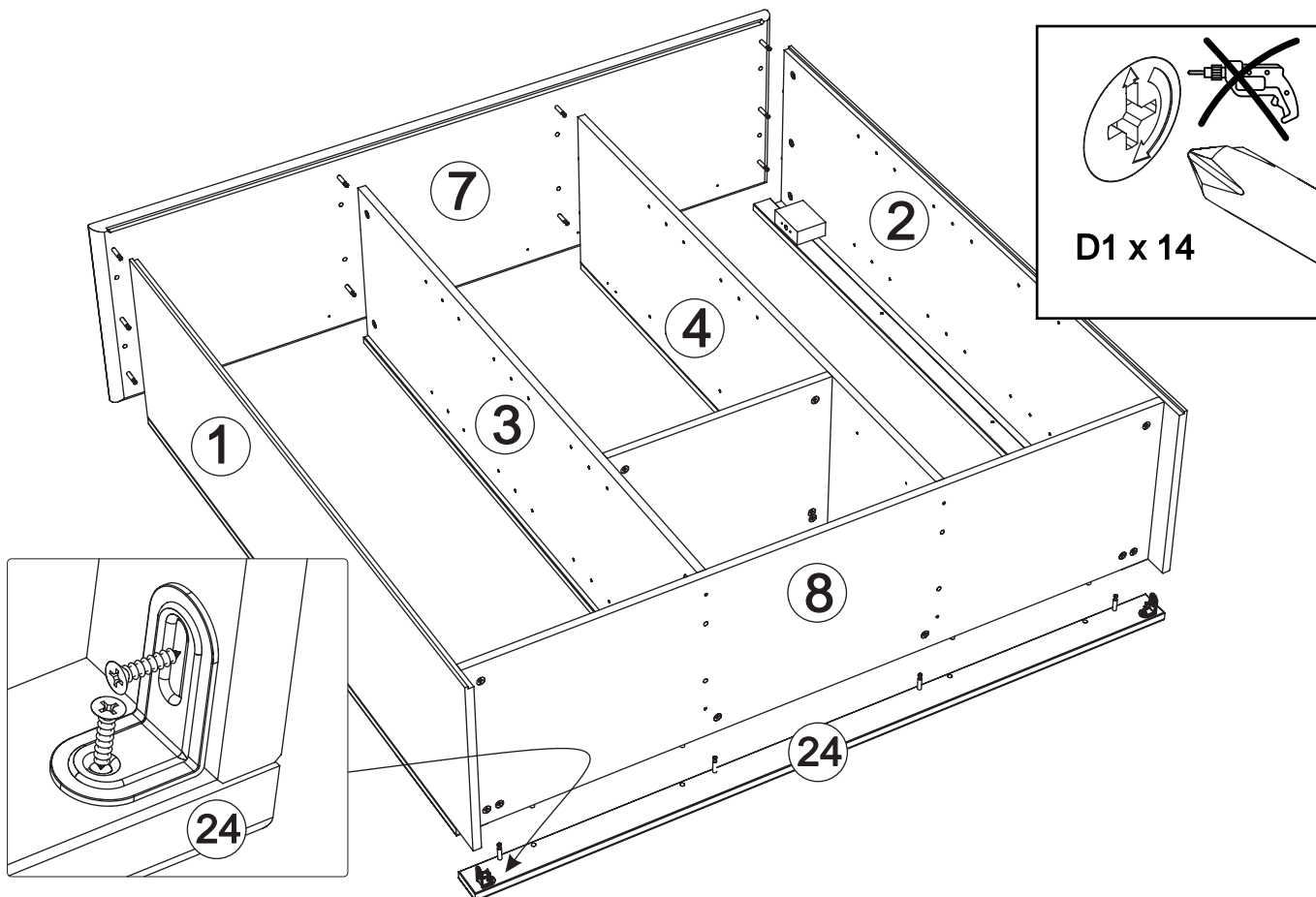

9 F11 x 41 E2 x 10 H5 x 10 X1 x 4

PZ1

!
X = Y

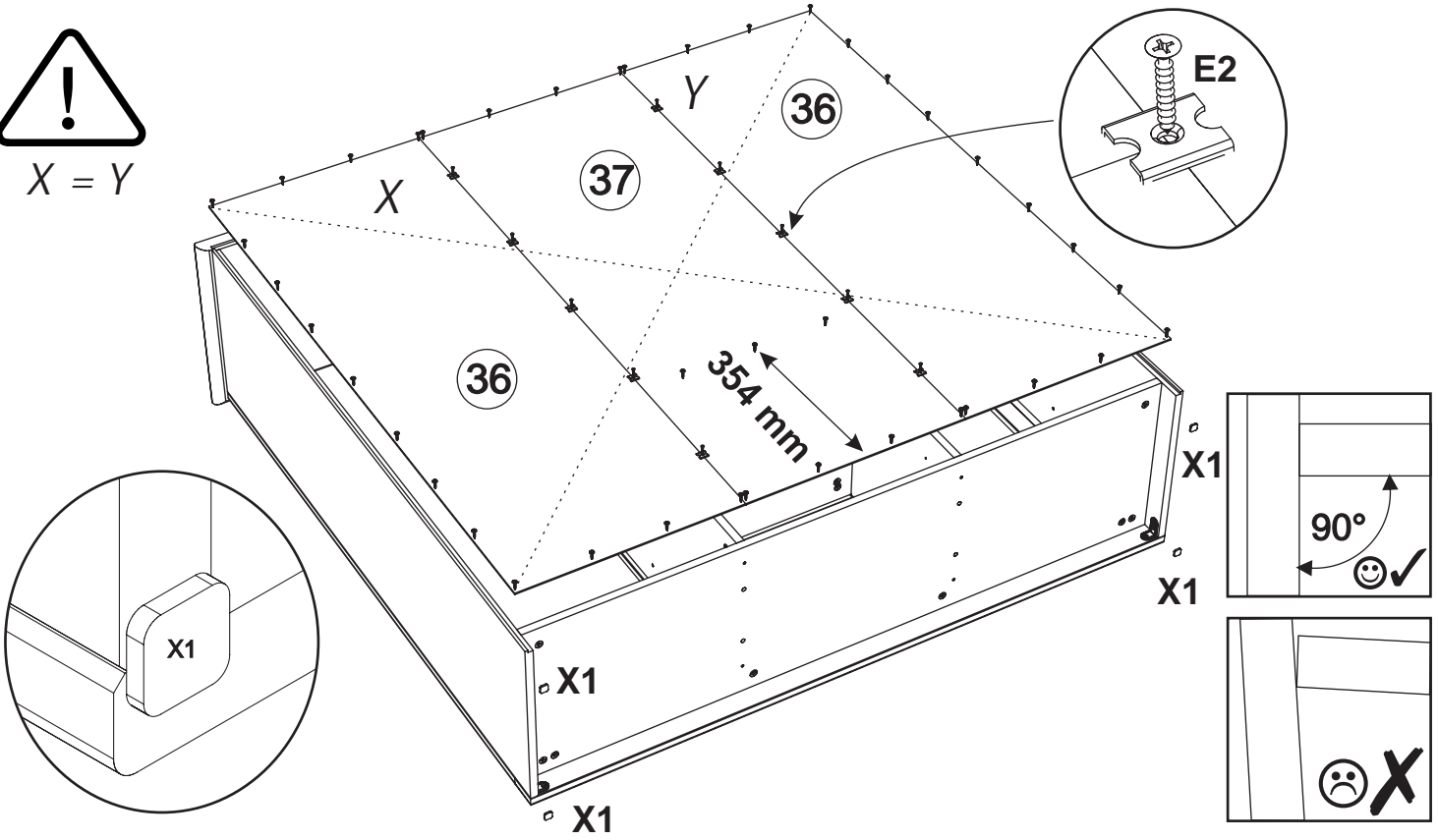

10 F6 x 12

PZ2

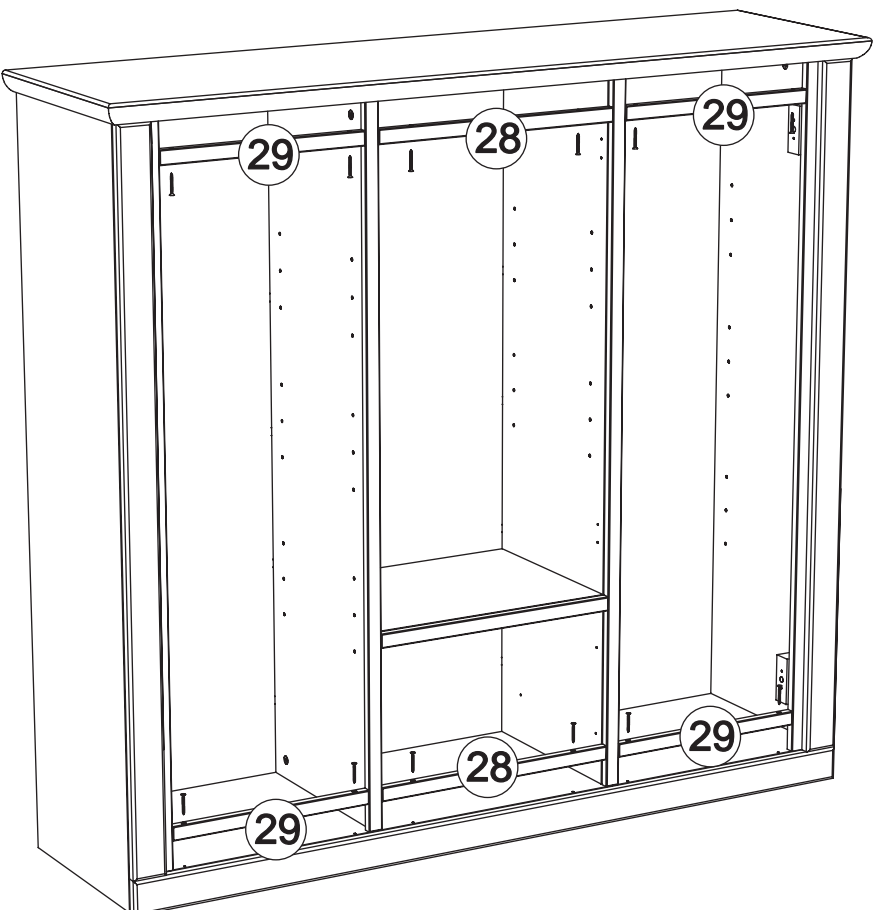

11

F2 x 8

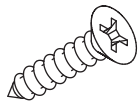

W5 x 4

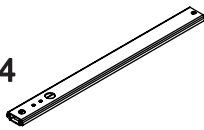

PZ2

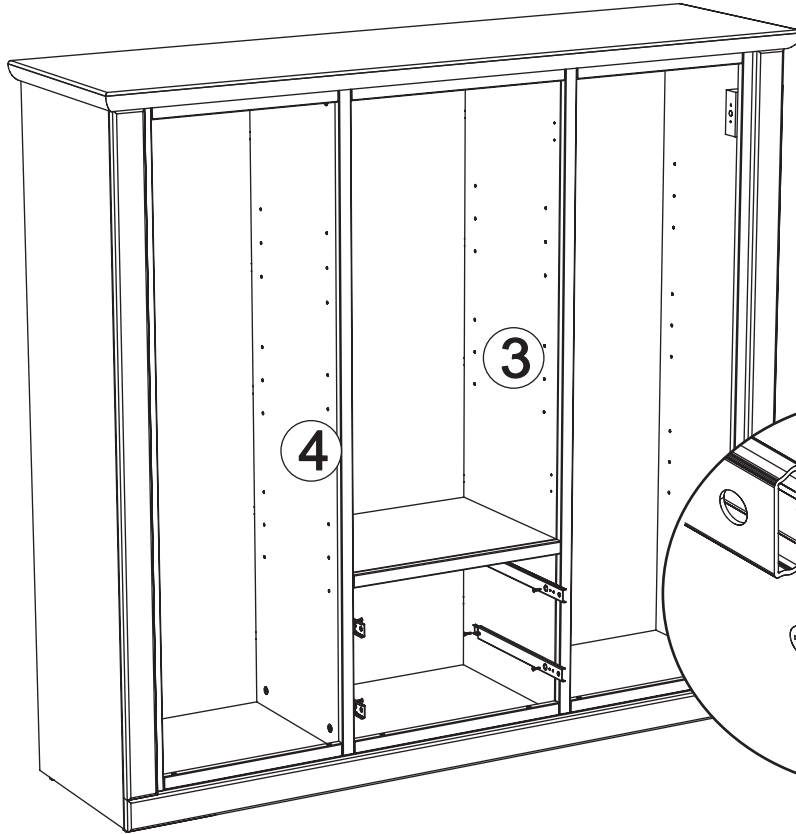

W5 x 4+
F2 x 8

12

F2 x 12

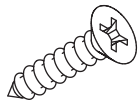

P13 x 6

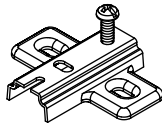

PZ2

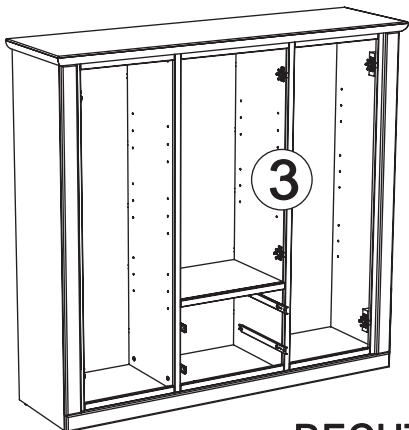
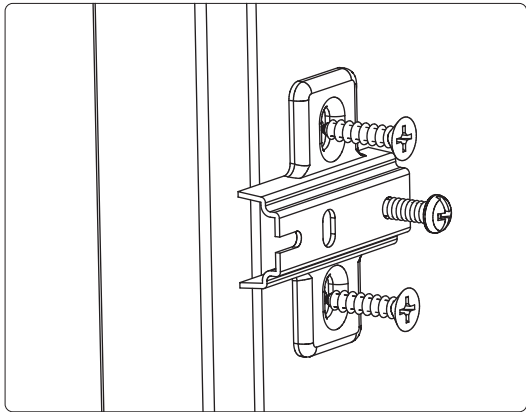

RECHT ver.

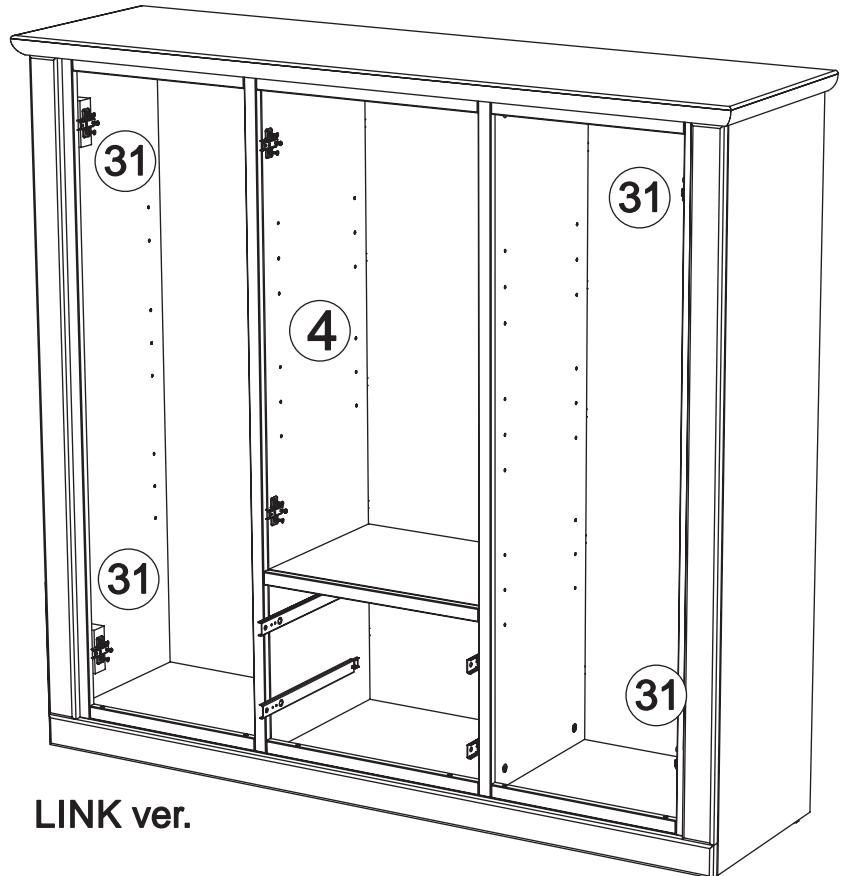

LINK ver.

13

B1 x 4

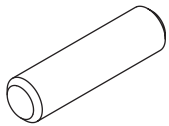

D1 x 4

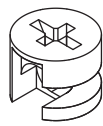

C1 x 4

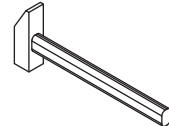
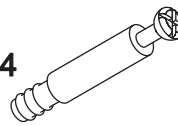

PZ2

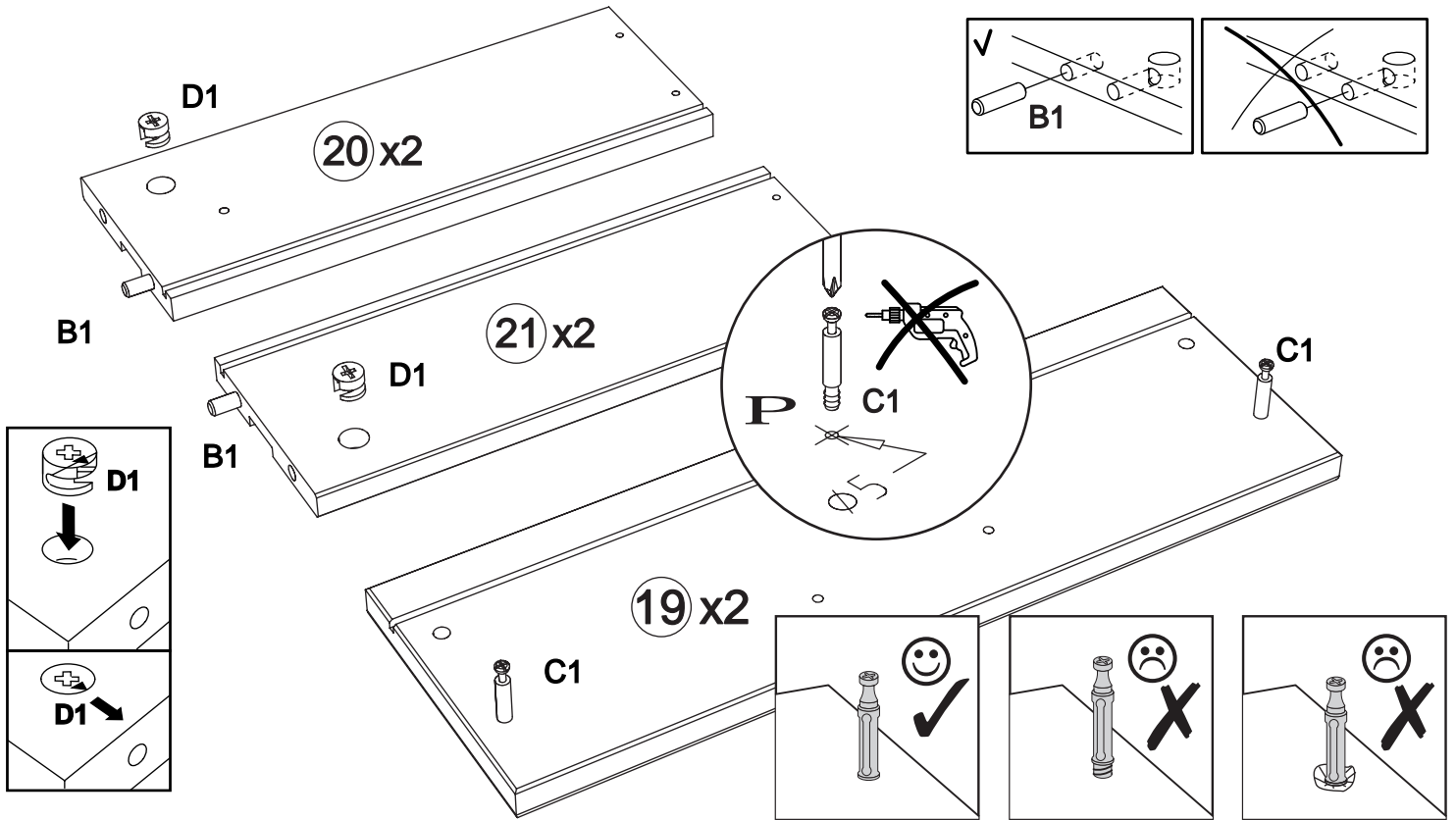

14

E5 x 8

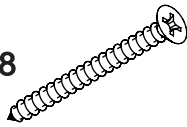

PZ1

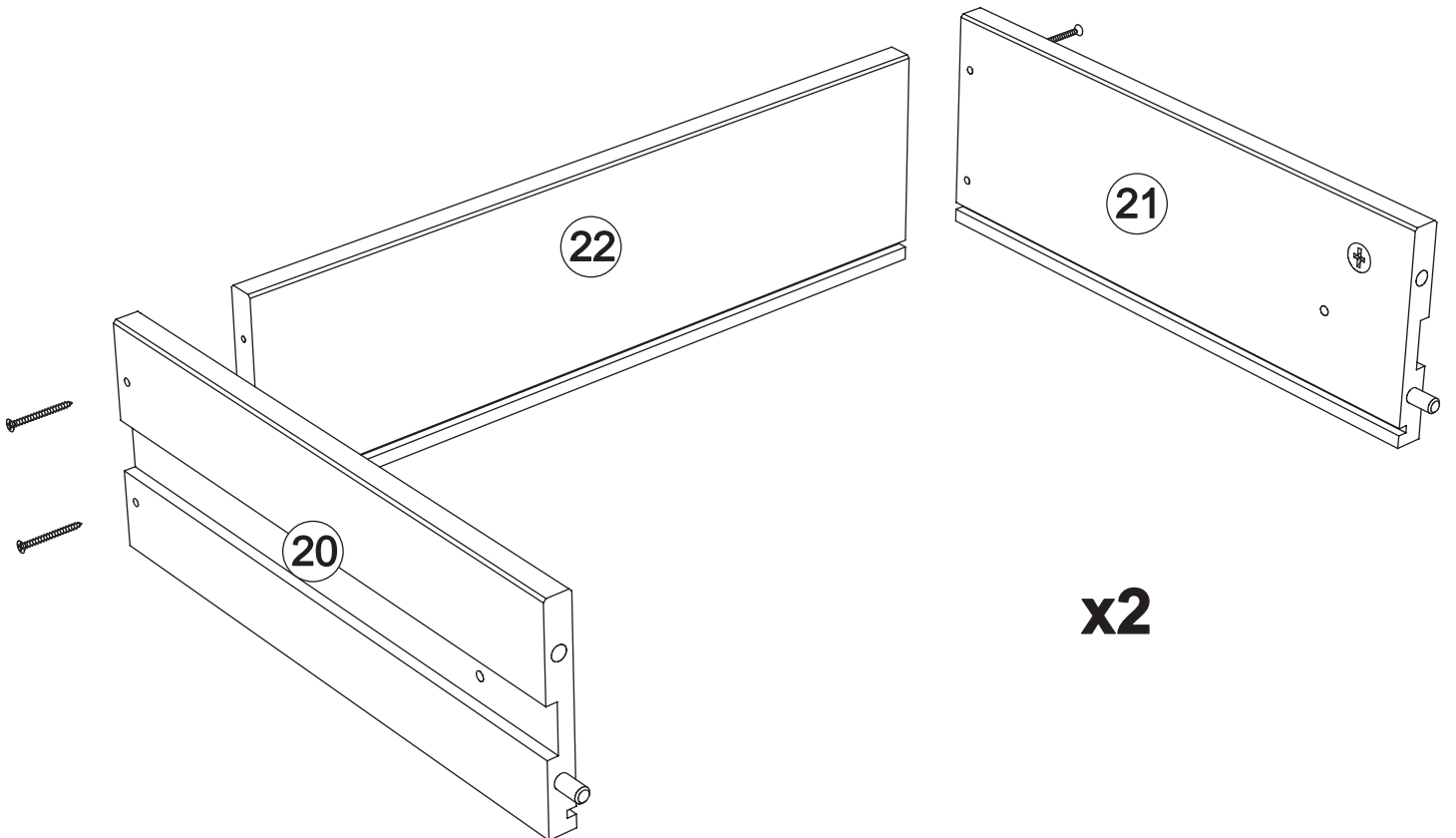

15

D3 x 4

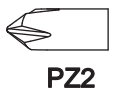
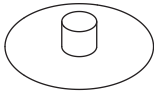

PZ2

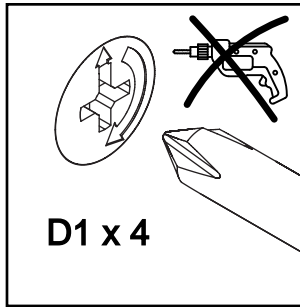

D1 x 4

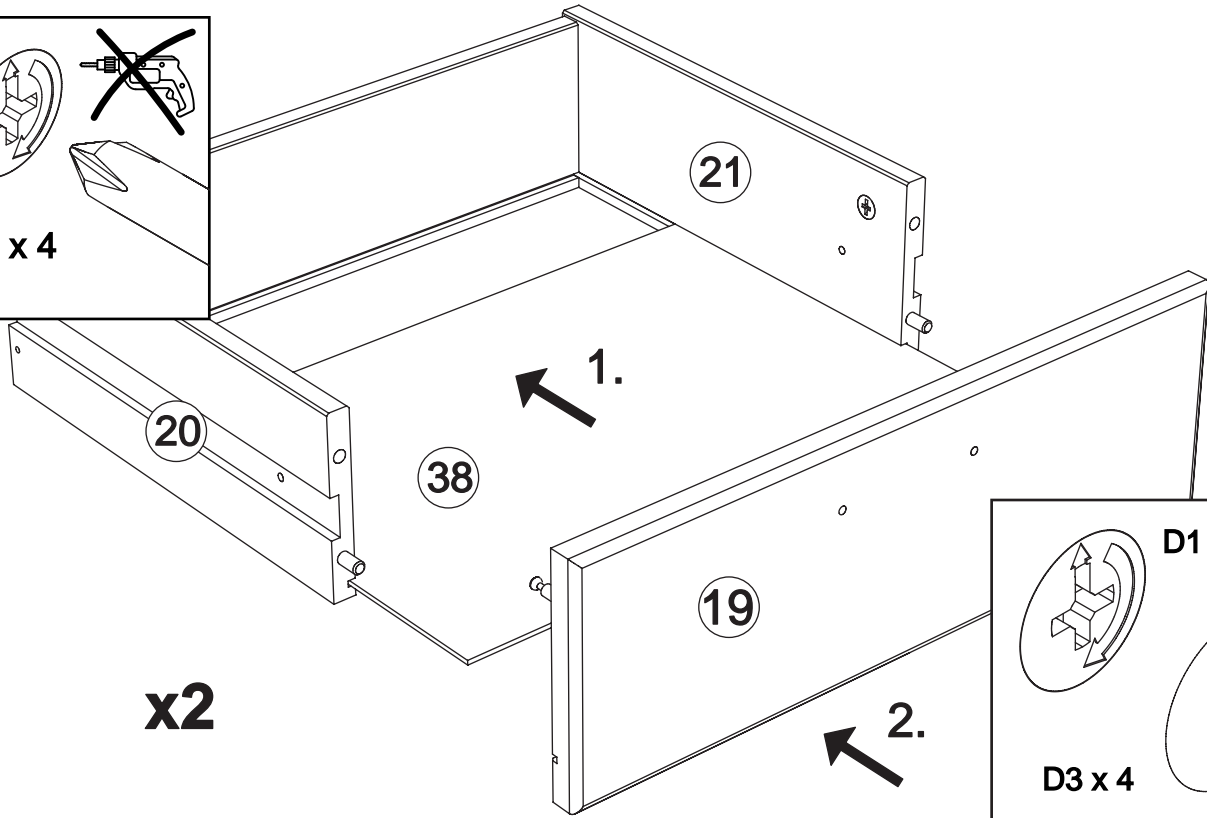

x2

D1

D3 x 4

16

J19 x 4

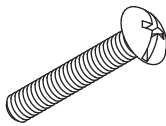

R17 x 2

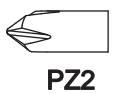
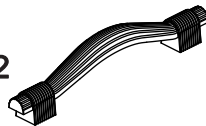

PZ2

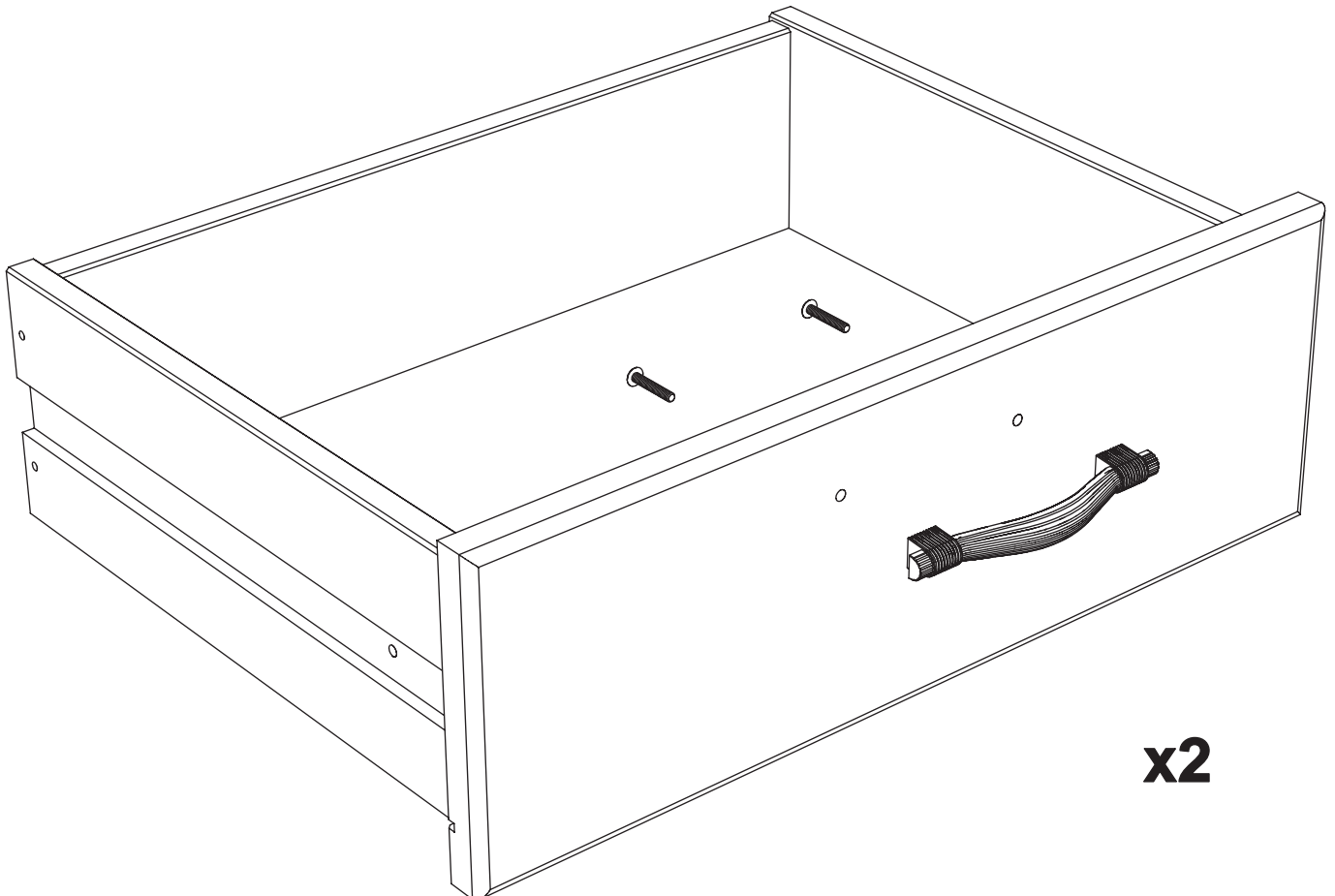

x2

17

J1 x 4

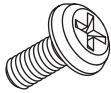

PZ2

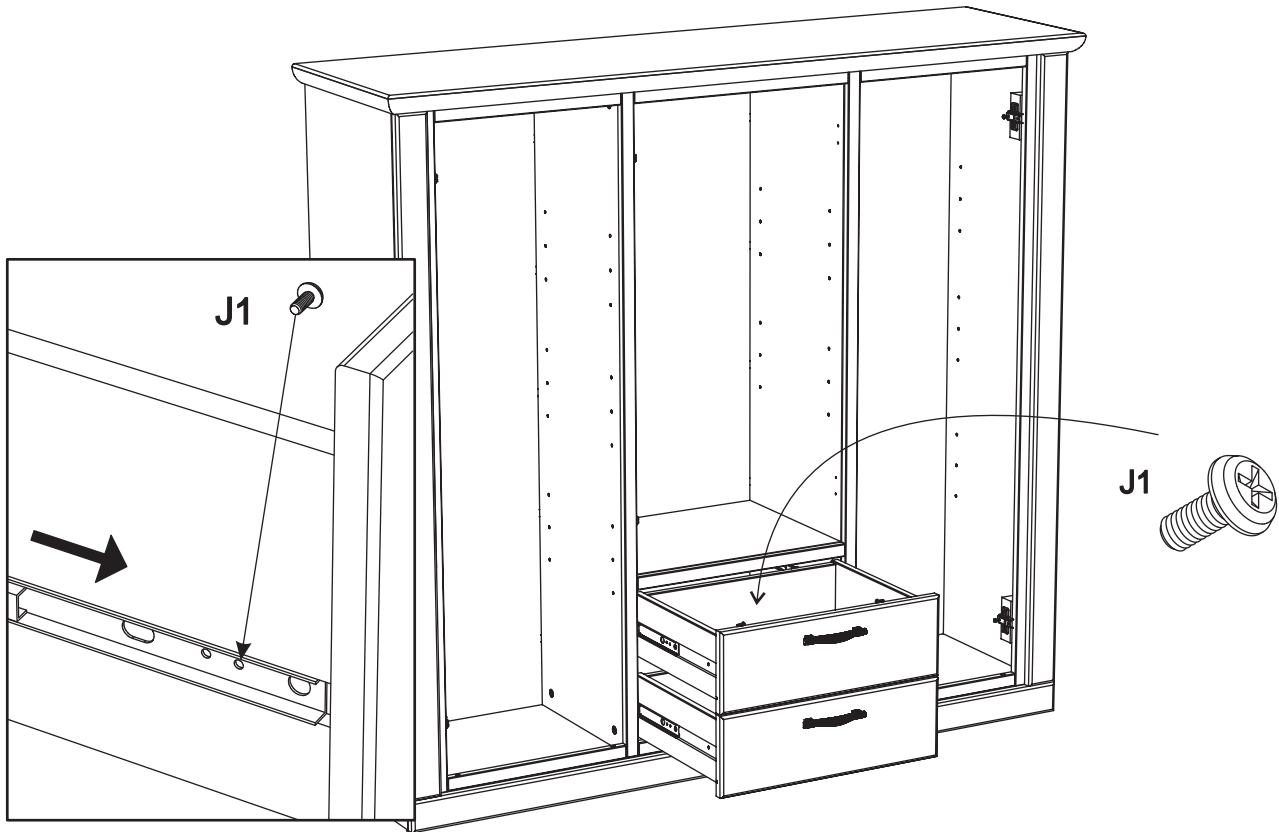
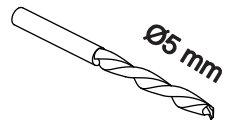
**18**

!!! ACHTUNG:
 Bei der MONTAGE DER GRIFFE
 unbedingt darauf achten, dass beim
 Nachbohren oder Durchstechen der
 vorgebohrten Löcher von vorne
 ein Holzstück oder ähnliches
 dagegen gehalten wird. Damit
 ein Ausspalten verhindert wird.
 Aufpassen, dass die richtigen
 Löcher verwendet werden.

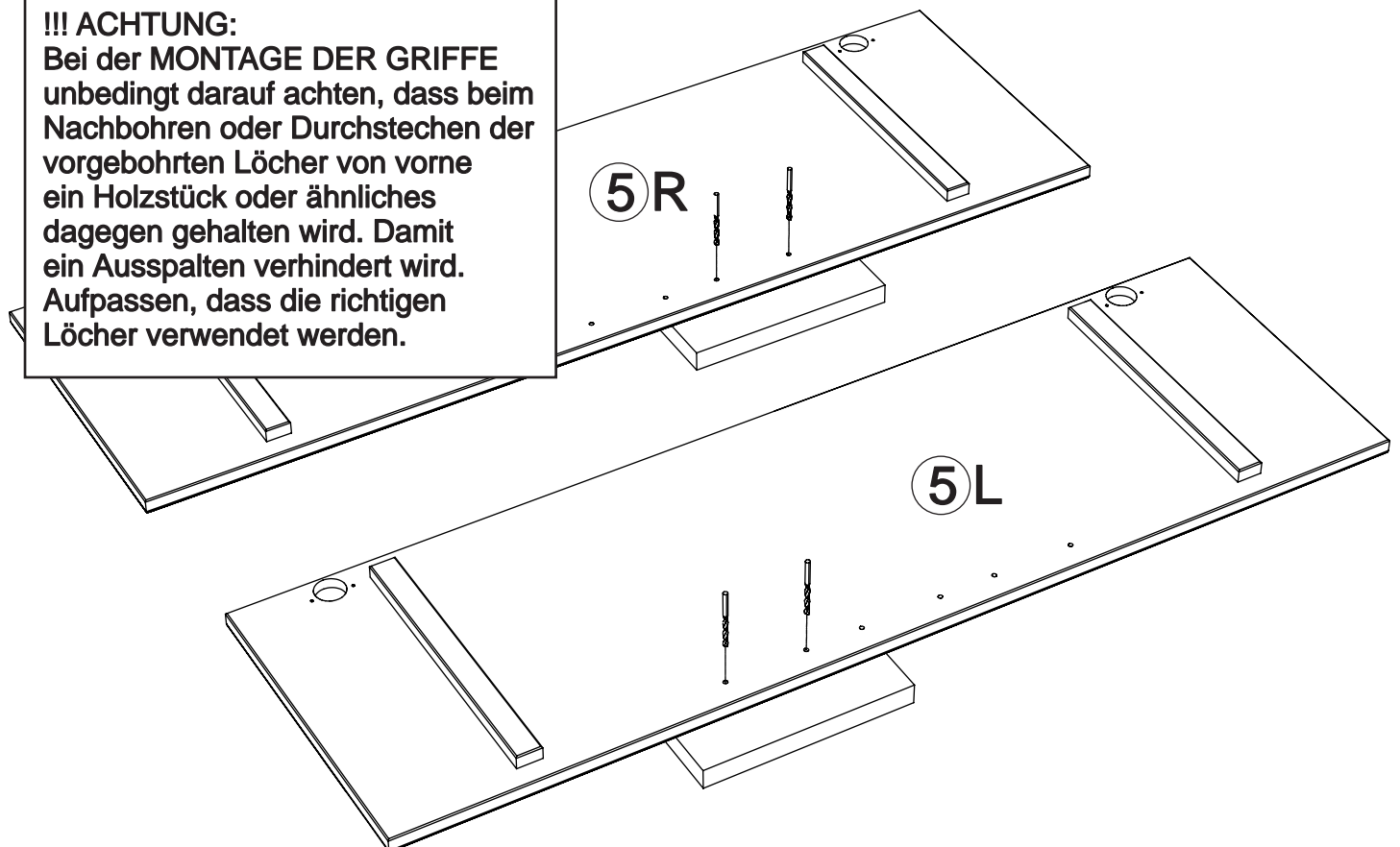

19

F2 x 12

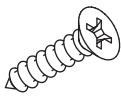

V22 x 6

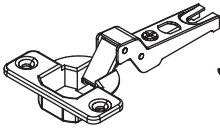

J19 x 6

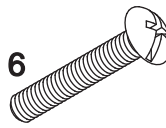

R17 x 3

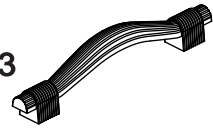

PZ2

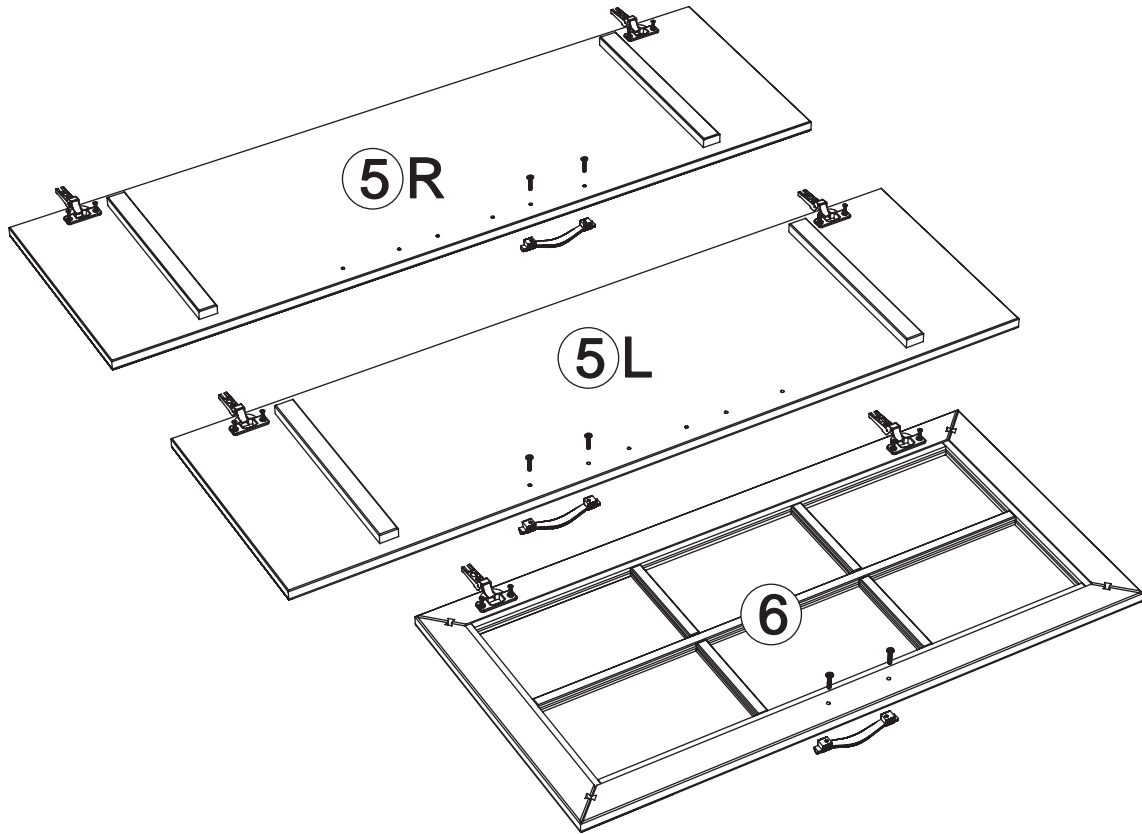

20



PZ2

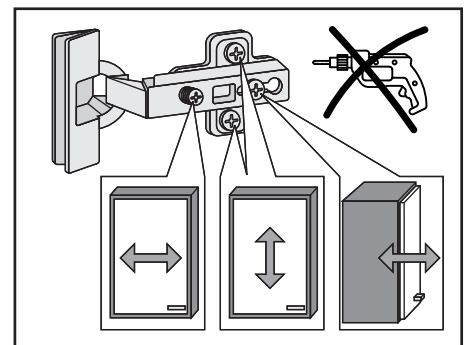
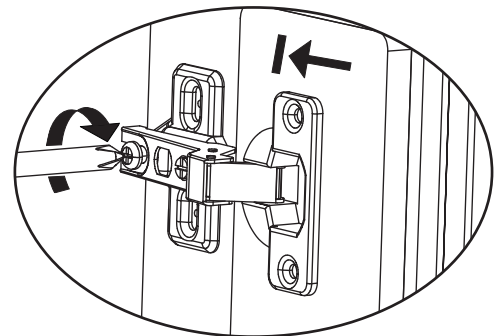
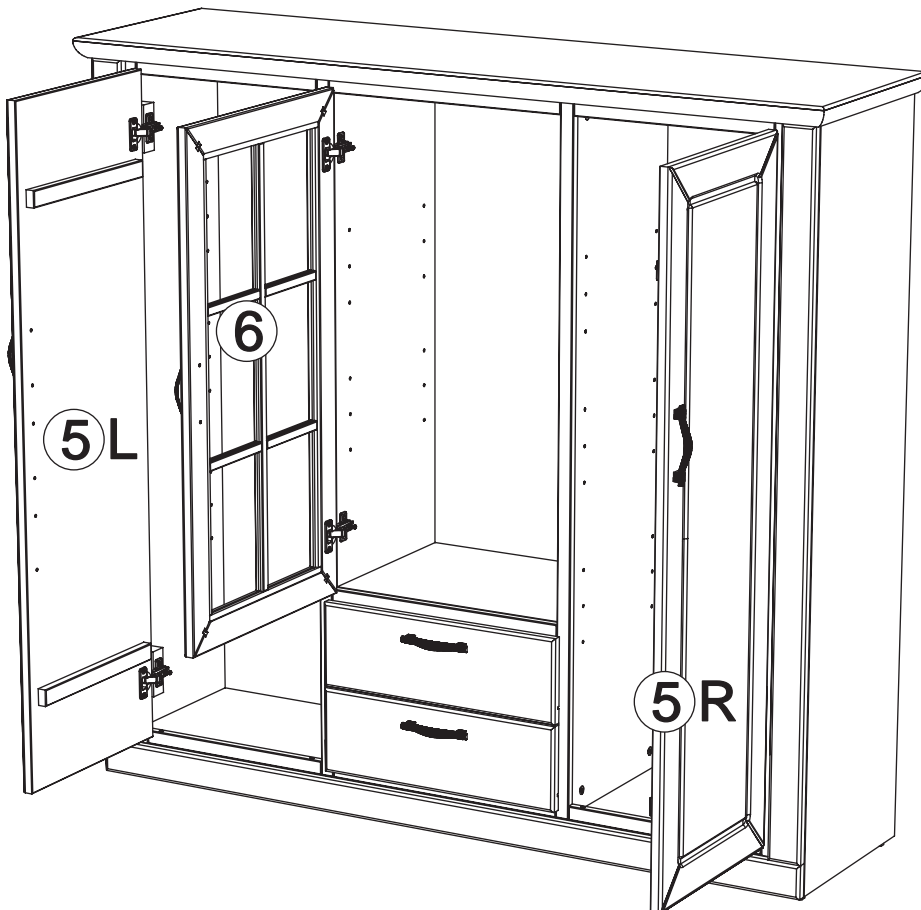

21

Q1 x 32



D3 x 14



F2 x 1



G9 x 1

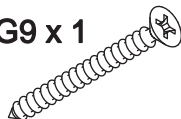

B10 x 1

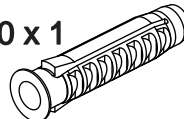

L15 x 1

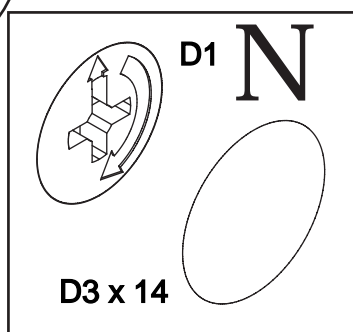
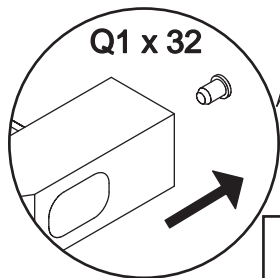
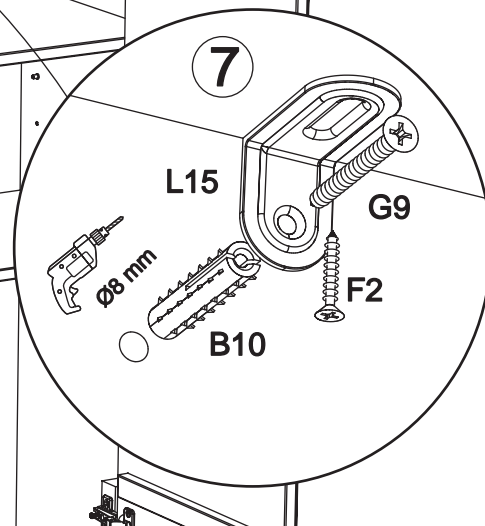
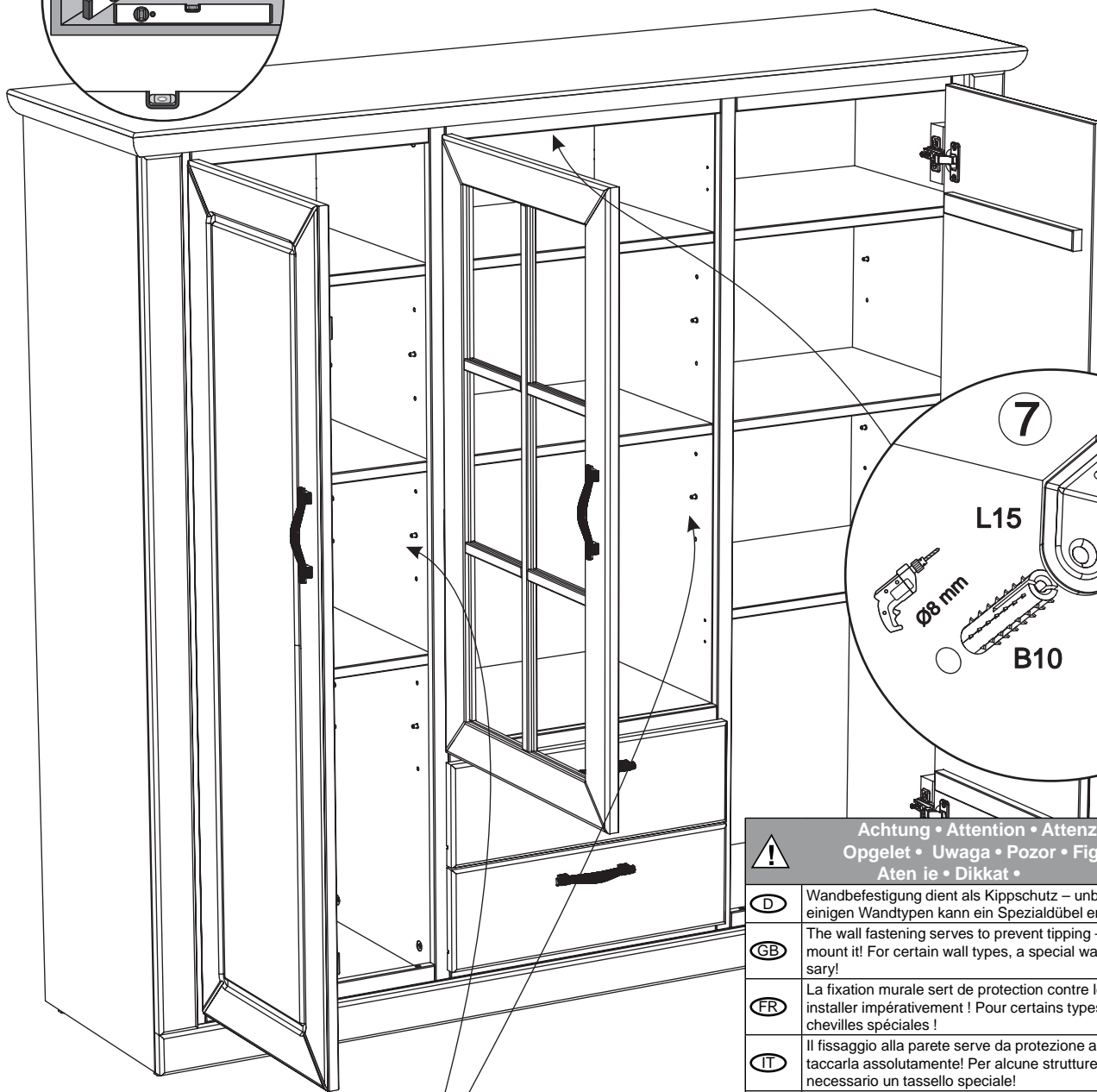
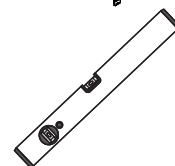
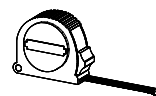
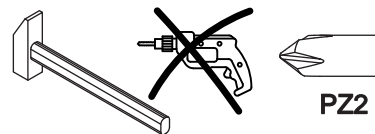
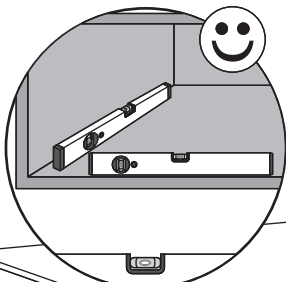

⚠ Achtung • Attention • Attenzione ⚠ Opgelet • Uwaga • Pozor • Figyelem ⚠ Aten ie • Dikkat • ⚠	
(D)	Wandbefestigung dient als Kippschutz – unbedingt anbringen! Bei einigen Wandtypen kann ein Spezialdübel erforderlich sein!
(GB)	The wall fastening serves to prevent tipping – be absolutely sure to mount it! For certain wall types, a special wall plug may be necessary!
(FR)	La fixation murale sert de protection contre le basculement – à installer impérativement ! Pour certains types de murs il faut des chevilles spéciales !
(IT)	Il fissaggio alla parete serve da protezione anti-ribaltamento – attaccarla assolutamente! Per alcune strutture di parete può essere necessario un tassello speciale!
(NL)	Bevestiging aan de muur dient als kantelbescherming – zeker en vast bevestigen! Bij enkele muurtypes is een speciale plug misschien vereist!
(PL)	Mocowanie do ściany jest jednocześnie zabezpieczeniem przed przewróceniem – konieczne zamontować! Do niektórych rodzajów ścian konieczne zastosować specjalne kołki mocujące.
(CZ)	Montáž na stěnu slouží jako ochrana proti převrnutí – bezpodmínečně umístěte! U některých typů stěn může být zapotřebí speciální hmoždinka!
(SK)	Upevnenie na stenu slúži ako ochrana proti prevráteniu – bezpodmienečne použite! Pre niektoré druhy stien môže byť potrebná špeciálna hmoždinka!
(HU)	A termék a falhoz való rögzítése, különben az felborulhat! Egyes fal típusoknál speciális tiplét kell használni!
(RO)	Sistemul de fixare la perete serve te ca protecție la răsturnare – de montat obligatoriu! Pentru unele tipuri de pereți este posibil să fie necesar un diblu special!
(TR)	Duvardaki sabitleme, devrilmeye karşı bir emniyet tedbiridir ve mutlaka monte edilmelidir! Bazı duvar tiplerinde bunun için özel bir dübel gereklidir!
(RU)	!